

FREQUENCY INDEPENDENT DATA

Description: directional stacked yagi array, field adjustable pattern, optional beam tilting

Frequency: 135-145 MHz, 144-156 MHz, 154-166 MHz, 163-177 MHz, 221-239 MHz, 326-353 MHz, 336-364 MHz, 365-395 MHz, 380-410 MHz, 405-440 MHz, 440-475 MHz, 806-870 MHz, 830-890 MHz, 880-960 MHz

Impedance: 50 ohm

Gain: 11 dBi

H -3 dB: 85°

E -3 dB: 26°

F/B: 12 dB

Polarization: vertical/horizontal

Connector: N-female/TNC-female

VSWR: < 1.5

Radome: UV resistant ABS/FG, RAL 7012, PU foam filling

Radiator: copper

Passive elements: coated aluminium

Attachment: Ø 35-60 mm, aluminium alloy bracket, stainless steel V-bolts and self-locking nuts

Lightning protection: DC-short circuited
Temperature: -40°C - +80°C

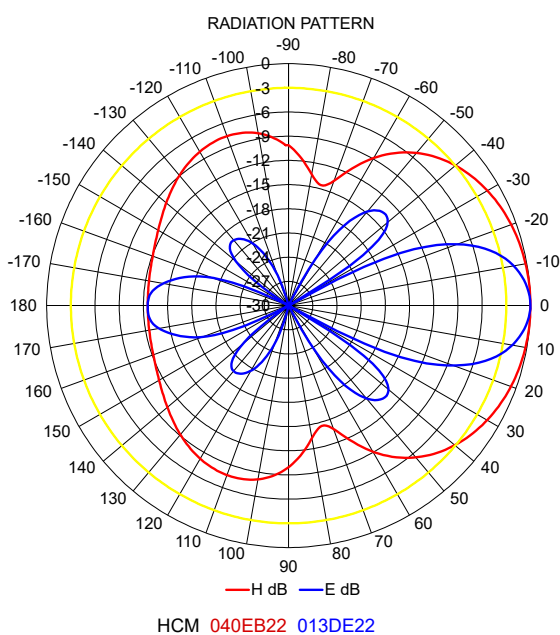
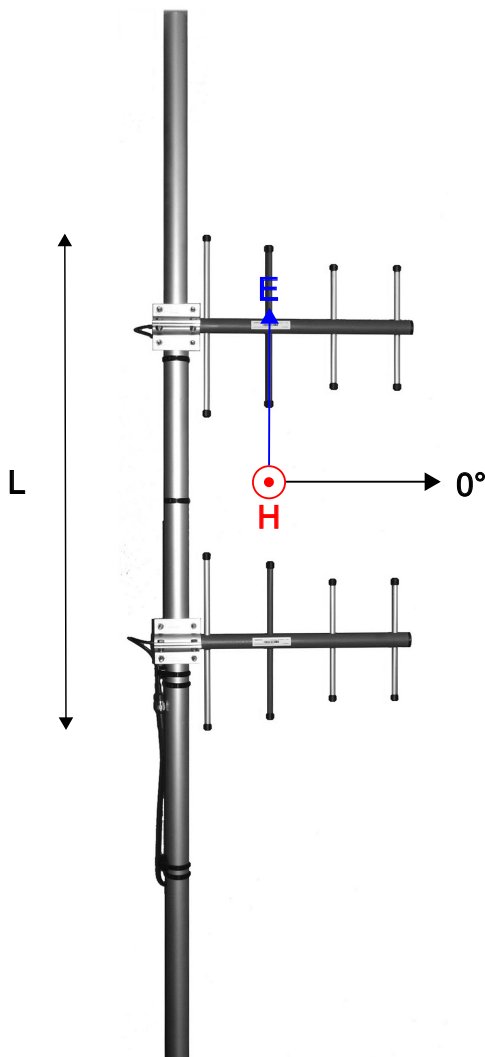

- combination of durability, light weight and low wind load
- radome enclosed radiator
- IP67 proof construction
- all electromechanics moulded inside of closed cell PU foam
- DC shorted feed point
- integrated impedance compensation
- integrated RF choke